

# SMA Aluminum Cylinders



**PNEUMATIC TO  
200 PSI  
HYDRAULIC 250  
TO 400 PSI Non shock**

**1 1/8", 1 1/2",  
2", 3" BORE**

**SPACE SAVING  
AND CONVENTIONAL  
DESIGNS**

**REPAIRABLE**

**Very high quality "Pancake" type cylinders with all of the engineering features you need to outpace the competition – generous bearing lengths, rod wipers, chromed shafts, superior seals and materials throughout.**

— PLUS —

**Cylinders of conventional length with longer bearings and increased distance between support points which provide exceptional service where space permits. U cup piston optional.**

## A GRAPH OF CYLINDER LENGTH vs QUALITY . . .

**Conventional  
Pancake**

*Too short to provide rod wipers, adequate bearing length, and quality seals. Length too short to provide end caps of sufficient strength for many applications. Piston rod wrench flats virtually unusable without special thin wrenches. Suitable for light duty pneumatic applications only.*



**SMA Short Mount**

*"Common sense engineered" to the shortest length possible without sacrificing areas critical to high performance. Excellent for both pneumatic and hydraulic service.*



**SMA Conventional Mount**

*Premium material in generous proportions yet small enough to fit.*

**Crimped Stainless Non Repairable**

*Although significantly longer, they fall short in design and materials.*

**N.F.P.A. Tie Rod Cylinder**

*Conventional design is too long and too costly for many applications.*

0" 1" 2" 3" 4" 5" 6"

Cylinder body length 1 1/2" Bore 0" Stroke

# SMA DESIGN FEATURES

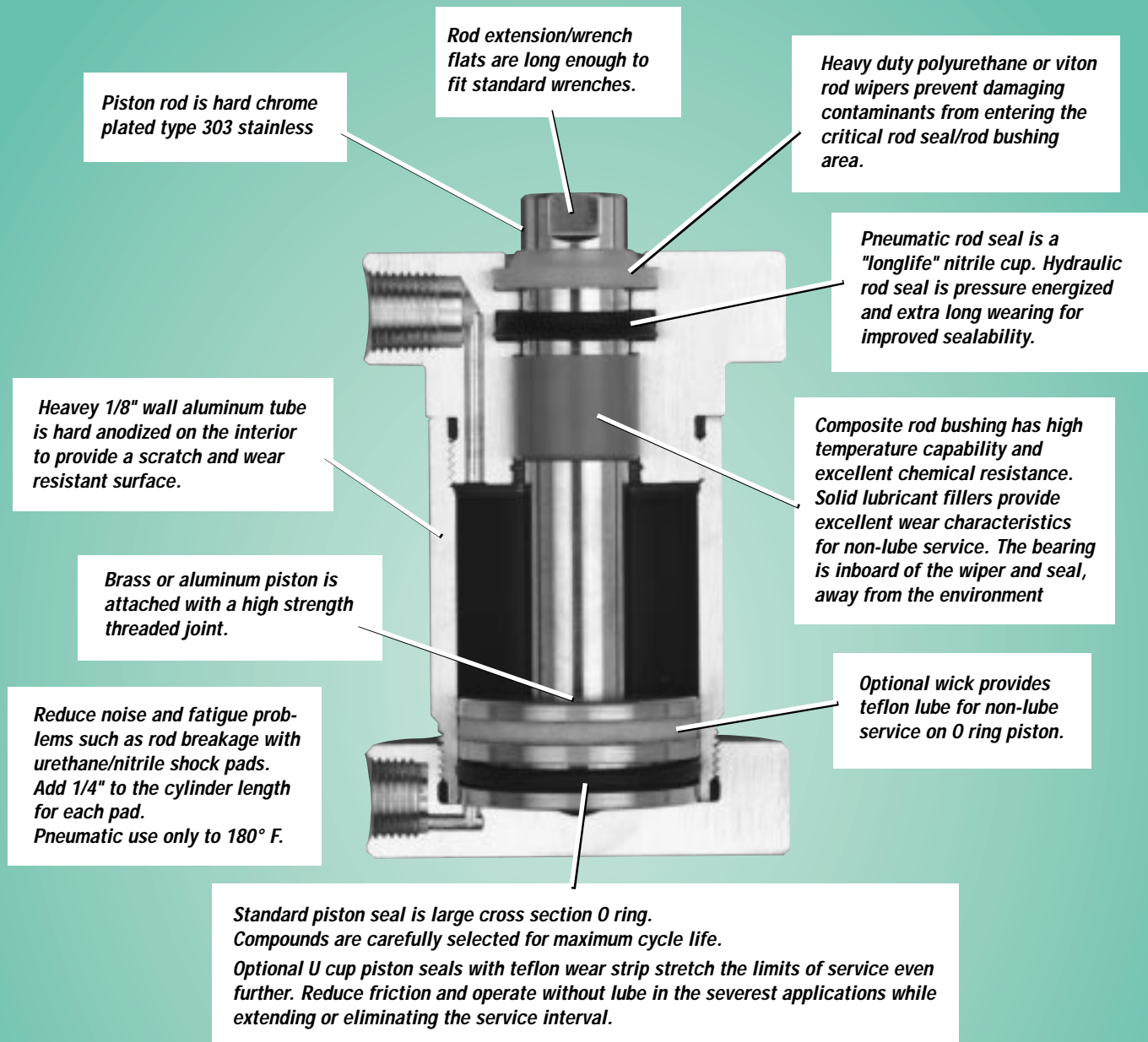

*If space permits for applications involving side loads or long strokes, select SMA 1, 2, 3, 5, 7, 8, 9, 12, 13, 19, 21, 23, 25, 28 which have extra long bearings with added space between support points.*

*Strokes longer than the maximum listed in the ordering procedure can be produced but careful consideration must be given to how the cylinder is applied — how well is the load supported or guided, is the cylinder used in push or tension, is the cylinder vertical or horizontal, etc. Consult factory on all strokes longer than standard. Stroke increments other than standard can also be made. Special lengths are generally available in a few days and are priced as "non-standard" strokes.*

**AIR PRODUCTS INC.**

TM

# 1 1/8" BORE SMA ALUMINUM

200 PSI MAX. AIR  
400 PSI MAX. HYD. Non shock

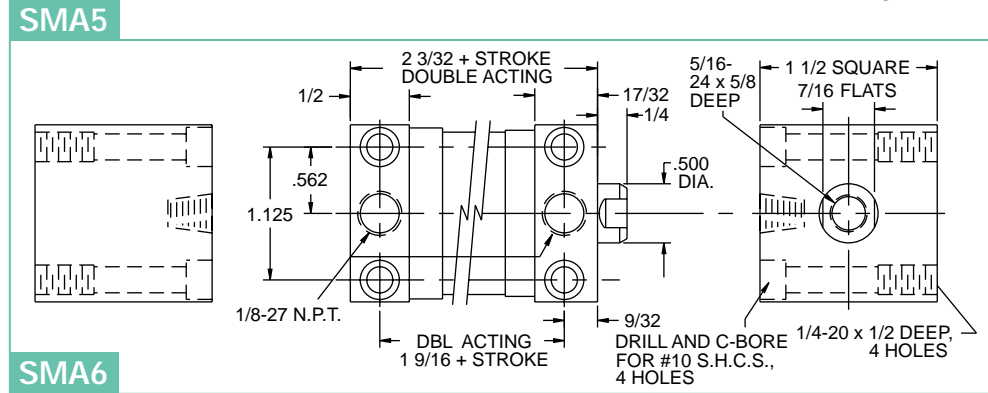
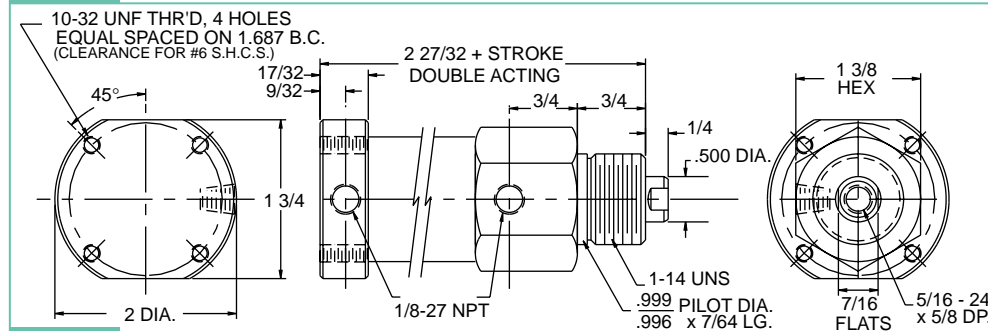
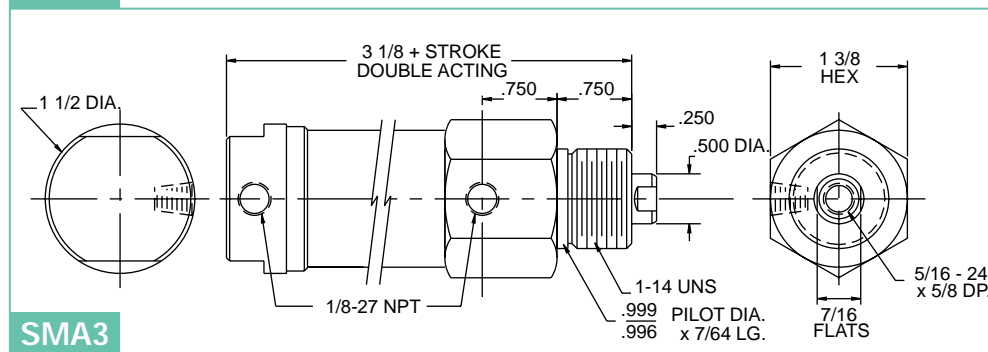
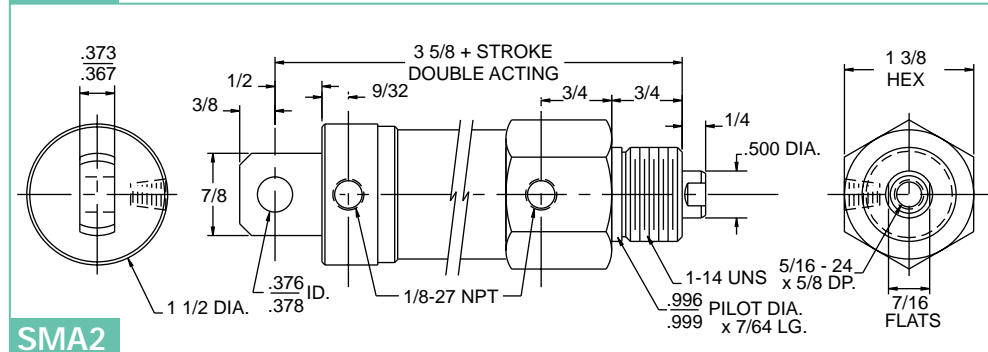
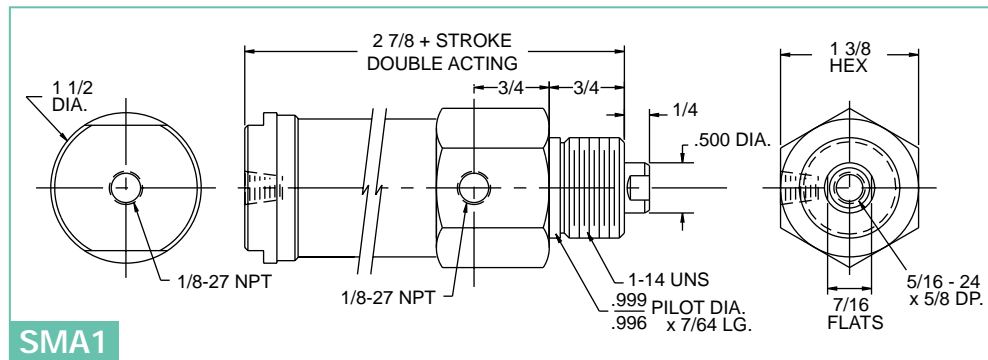

## Spring Return Cylinders

Pneumatic only  
Springs add to cyl. length  
0-2" stroke add 1 1/2" extra  
2 1/2-4" stroke add 3" extra  
over 4" stroke not available

Spring force  
Fully extended—8#  
Fully compressed—20#  
Spring material—Plated steel

## Optional Male Rod Thread

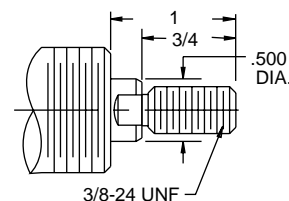

## 1-14 Nut Nose Mounting Nut

Not included with cylinder  
Order Separately

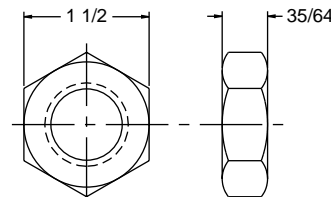

## HB-375 Rod Clevis & Nut

Zinc Plated Steel

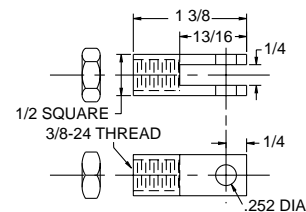

## HB-200 Clevis Pin Assembly

Used on HB 375  
Stainless Pin/Steel Clips



**SMA Options**

- Shock Pads
- Viton Seals
- Non-lube Service
- Magnetic Piston
- U Cup Piston
- Non-rotate (SMA 7,8,9)
- 90° Rear Clevis

**AURORA...  
BETTER BY  
DESIGN**

**STC-40**

**Low Profile Clevis Brk't**

Used on SMA 2  
Zinc plated steel

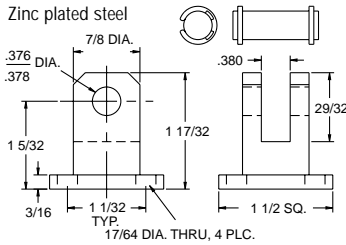

**HB-90**

**St'd Clevis Brk't**

Used on SMA 2  
Zinc plated steel

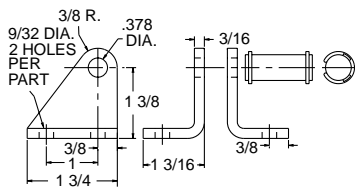

**HB-90T**

**Trunnion Bracket**

Used on SMA 10, 11  
Zinc plated steel

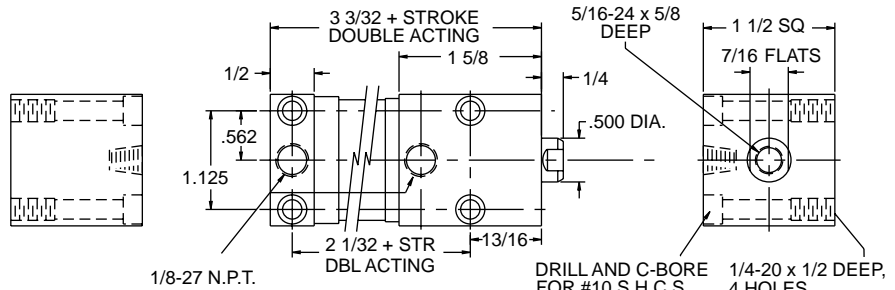
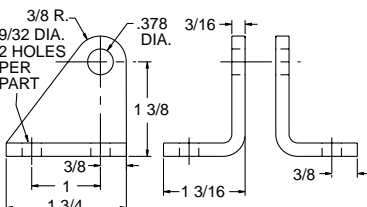

**SMA7**

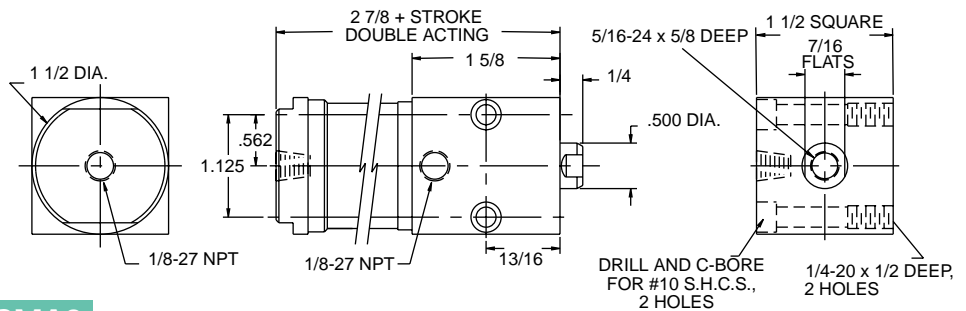

**SMA8**

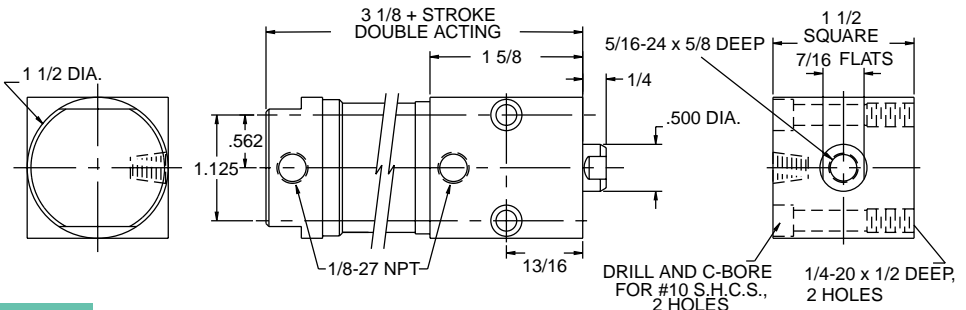

**SMA9**

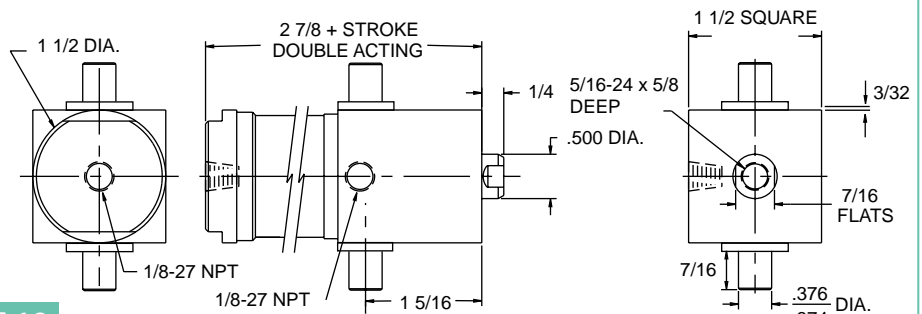

**SMA10**

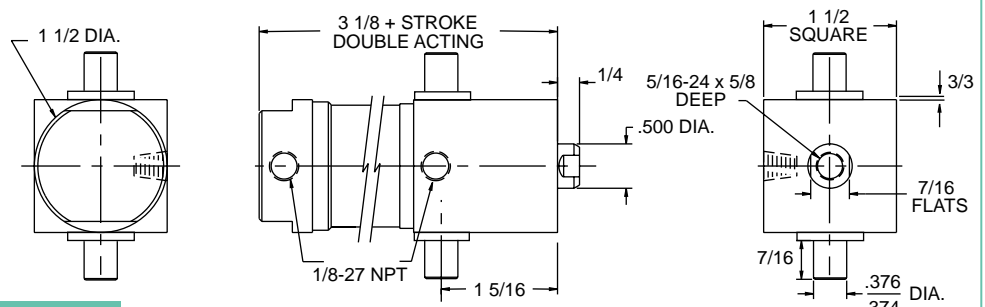

**SMA11**

# 1 1/8" BORE SMA ALUMINUM

200 PSI MAX. AIR  
400 PSI MAX. HYD. Non shock

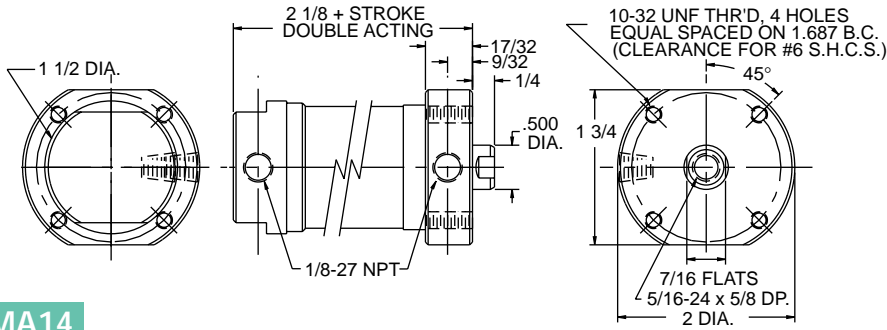

SMA14

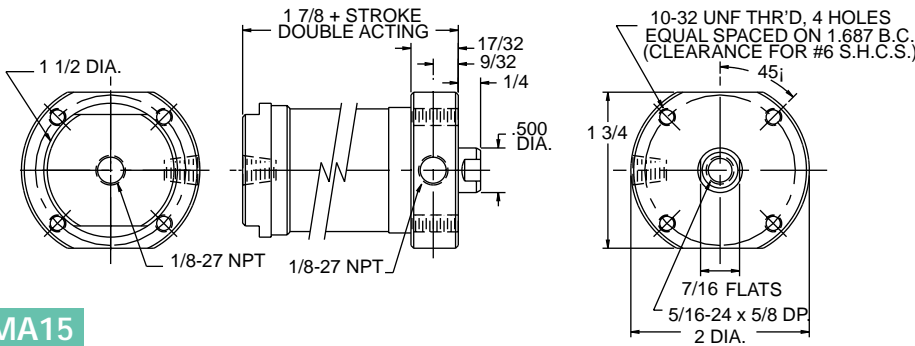

SMA15

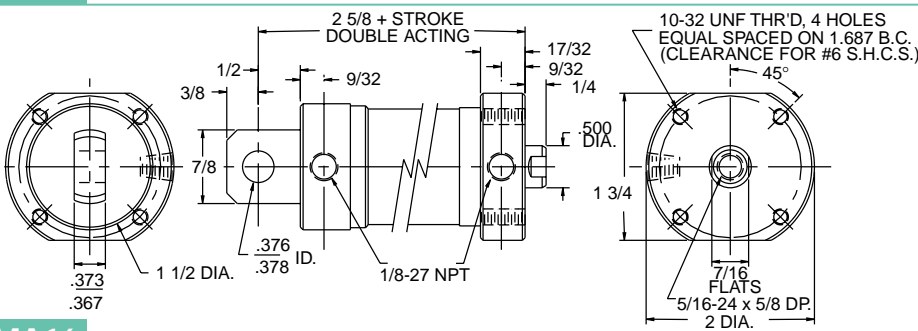

SMA16

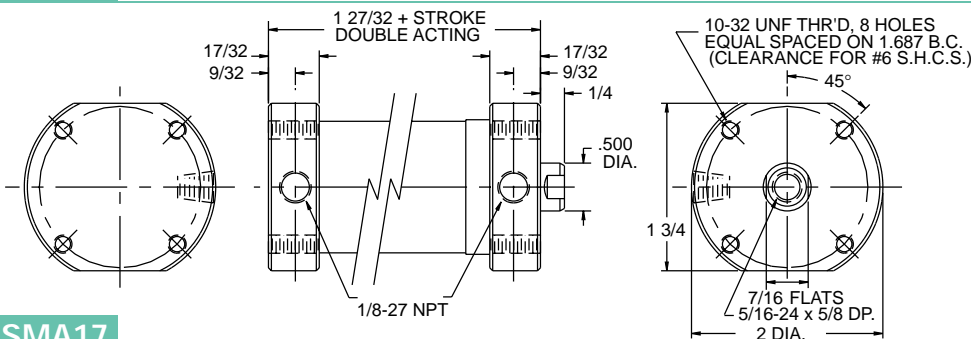

SMA17

*For the ultimate in cycle life or where side load exists  
select the U cup piston with teflon wear strip*

*Adds 1/2" to length*

## Spring Return Cylinders

Pneumatic only  
Springs add to cyl. length  
0-2" stroke add 1 1/2" extra  
2 1/2-4" stroke add 3" extra  
over 4" stroke not available

Spring force  
Fully extended—8#  
Fully compressed—20#  
Spring material—Plated steel

## Optional Male Rod Thread

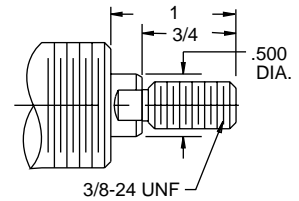

## 1"-14 Nut Nose Mounting Nut

Not included with cylinder  
Order Separately

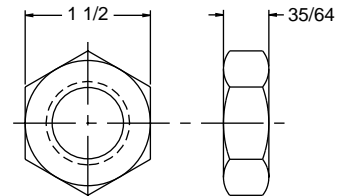

## HB-375 Rod Clevis & Nut

Zinc Plated Steel

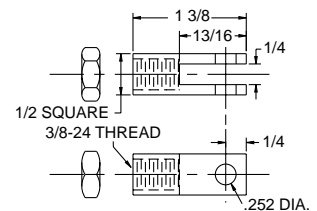

## HB-200 Clevis Pin Assembly

Used on HB 375  
Stainless Pin/Steel Clips





**Adjustable stroke models** – Adjustment screw prevents the piston from fully retracting. Maximum adjustment is 1"  
**Spherical mount models** – Eliminate side load where misalignment exists. Br'g is plated steel with teflon liner for non-lube service



Series SMA Aluminum

### SMA Options

- Shock Pads
- Viton Seals
- Non-lube Service
- Magnetic Piston
- U Cup Piston
- Non-rotate (SMA 12, 14, 15, 17, 20)
- 90° Rear Clevis

### STC-40 Low Profile Clevis Brk't

Used on SMA 16  
Zinc plated steel

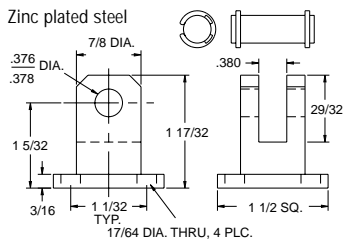

### HB-90 St'd Clevis Brk't

Used on SMA 16  
Zinc plated steel

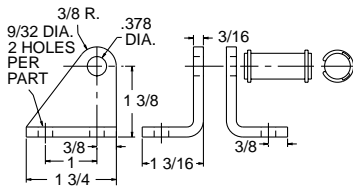

### SMA12

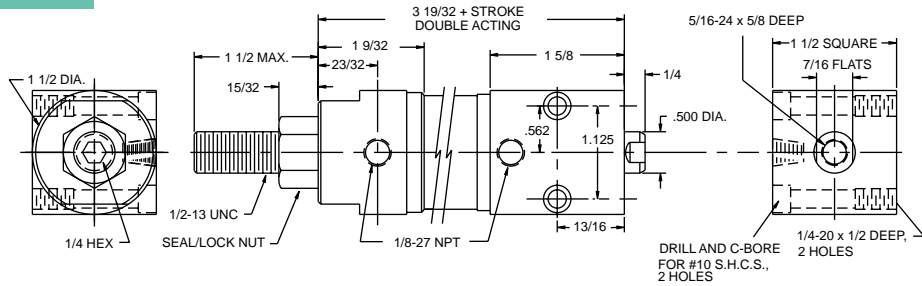

### SMA20

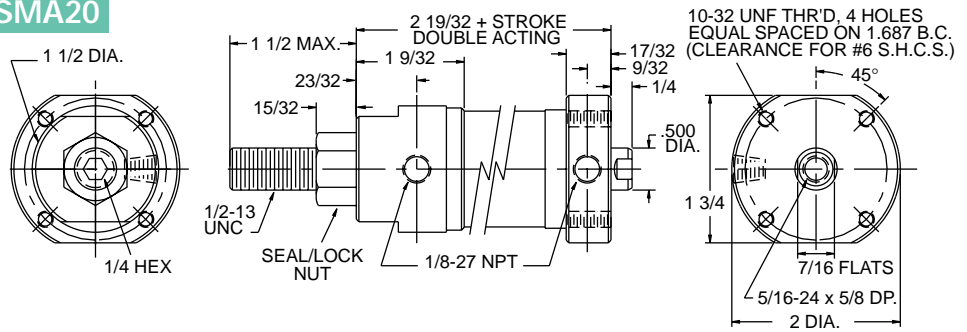

### SMA21

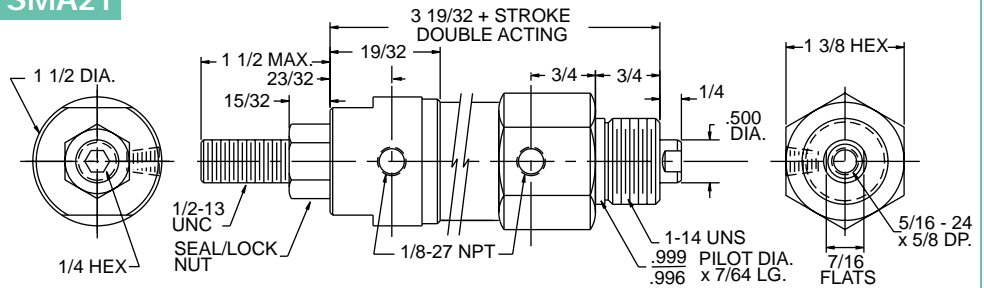

### SMA22

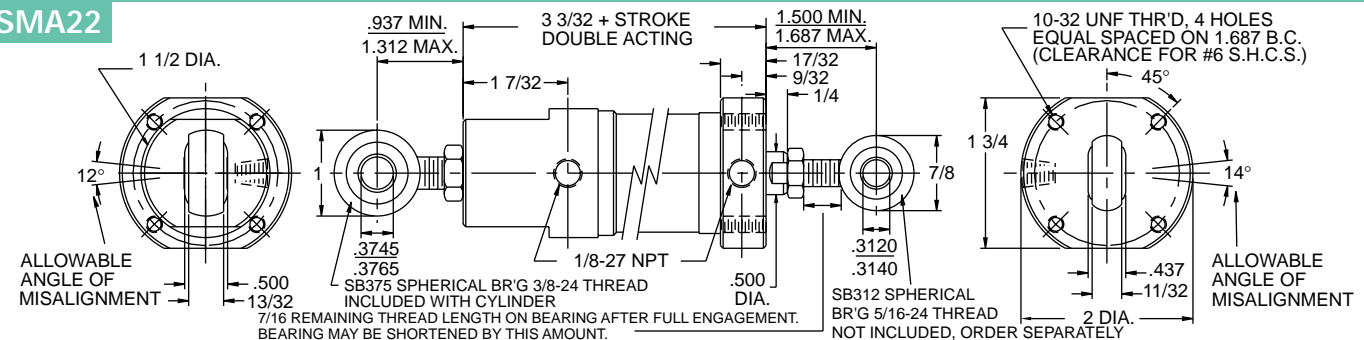

### SMA23

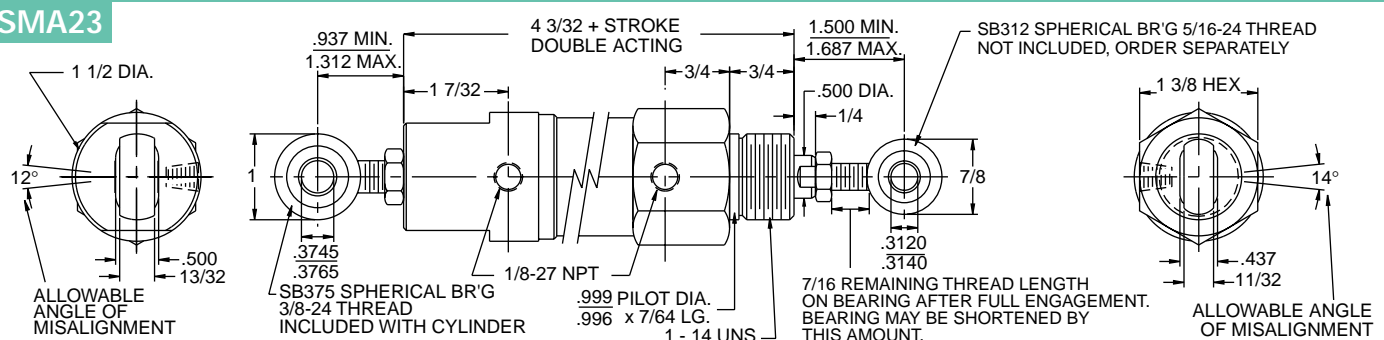

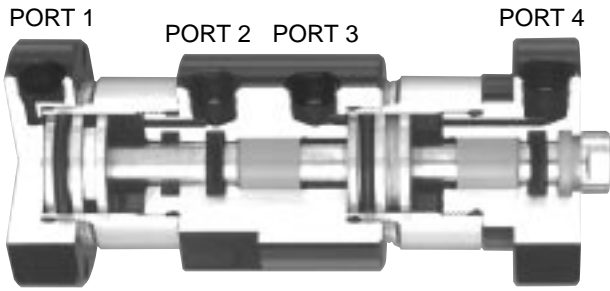

Three Position Cylinders are two in-line cylinders with a common cap but two separate and independent piston rods. By pressuring Port 1, 3, or 4, any combination of stroke 1 and total stroke may be achieved. Port 2 is a vent port only for Cylinder 1. In hydraulic applications it should be connected to a tank by a drain line.

Pressurize Port 1 and Cylinder 1 will extend pushing Cylinder 2 by the same amount. Then pressurize port 3 and Cylinder 2 will extend further to its maximum length. Pressurize Port 4 and both cylinders will retract.

\*Stroke of Cylinder 2 = TOTAL Stroke

EXAMPLE: If Cylinder 1 extends 2" when port 1 is pressurized, it will also push Cylinder 2 by 2". If, when Port 3 is pressurized, Cylinder 2 moves an ADDITIONAL 11/2". Then the total stroke of Cylinder 2 is 2" + 1 1/2" = 3 1/2". Always specify the stroke of Cylinder 2 as the total stroke.

### SMA24

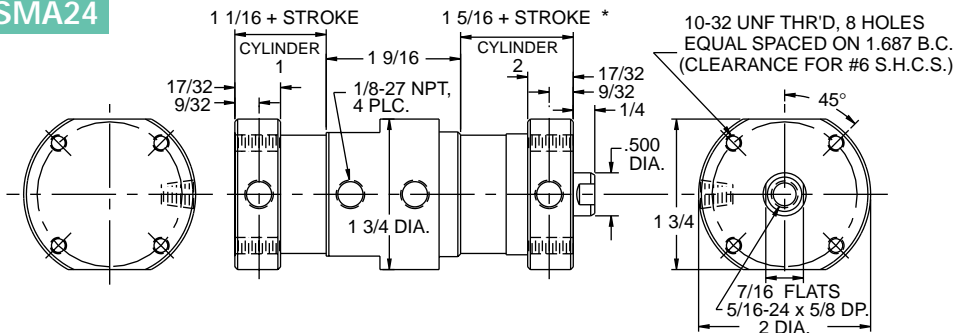

### Spring Return 3 Position

Pneumatic only  
Springs add to cyl. length  
Cyl. #1 and/or Cyl. #2  
0-2" stroke add 1 1/2" extra  
2 1/2-4" stroke add 3" extra  
over 4" not available  
Spring force  
Fully extended—8#  
Fully compressed—20#  
Spring material—Plated steel

### SMA25

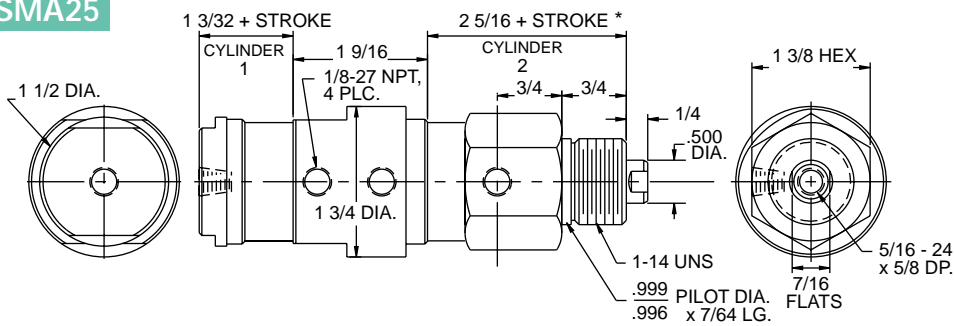

### Optional Male Rod Thread

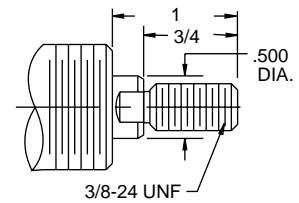

### SMA26

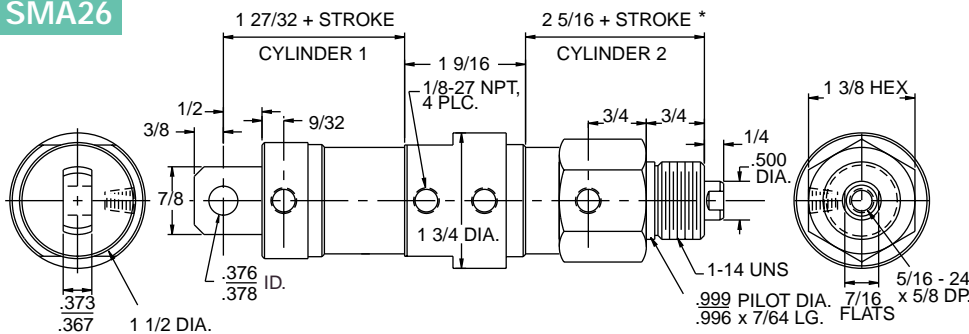

### 1"-14 Nut Nose Mounting Nut

Not included with cylinder  
Order Separately

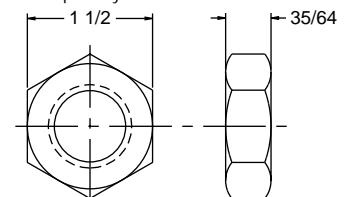

### SMA13

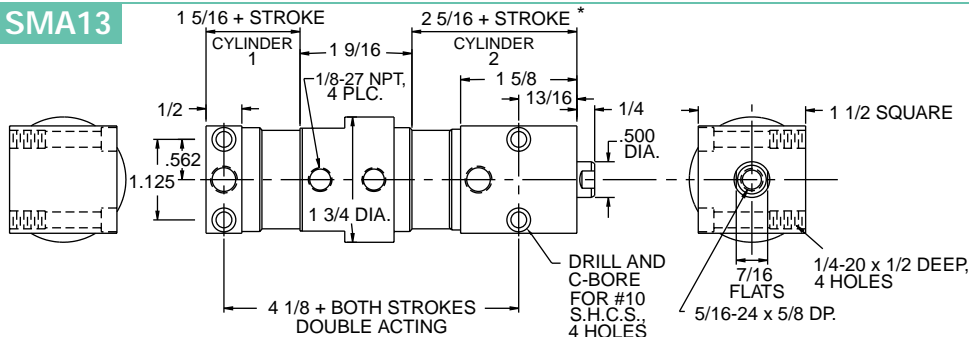

### HB-375 Rod Clevis & Nut

Zinc Plated Steel

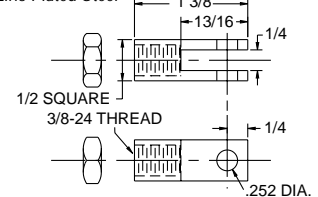

### HB-200 Clevis Pin Assembly

Used on HB-375 Stainless Pin/Steel Clips



# 1 1/8" BORE SMA ALUMINUM

**Tandem models** 200 PSI MAX. AIR  
400 PSI MAX. HYD. Non shock

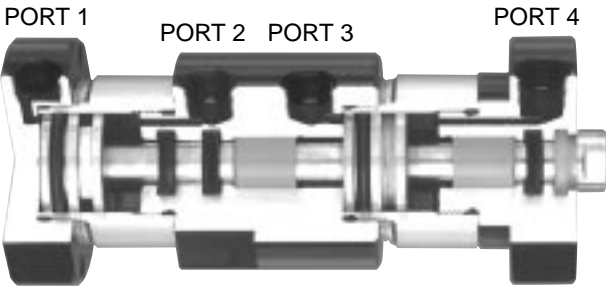

Tandem Cylinders are two in-line cylinders of the same stroke length with a common cap. Both pistons are attached to a common rod. By simultaneously pressurizing Ports 1 and 3 or 2 and 4, the force on the piston rod is nearly doubled. This can be useful when more force is required, but the diameter of the cylinder cannot be increased due to size restrictions.

Tandem cylinders can also be used as part of an air/oil system. Fill the front cylinder (Cyl.2) with oil and pipe its ports (3 & 4) in series using one or two flow controls. Using the rear cylinder (Cyl. 1) as an air powered driver, meter the oil from end to end on Cylinder 2. This will provide smooth, precise control of piston rod motion at all speeds.

A small reservoir of oil at 10-20 psi should be connected to Cylinder 2 if oil loss or expansion/contraction due to heat are a concern.

Tandem models double acting only  
Spring return not available

### 3 Position options

- Viton seals
- Non-lube service
- Magnetic piston
- U Cup piston
- Non-rotate (SMA 13, 24)
- 90° Rear clevis
- Shock pads not available

### Tandem options

- Viton seals
- Non-lube service
- 90° Rear clevis
- Shock pads not available
- Magnetic piston not available
- U cup piston not available
- Non-rotate not available

### SMA27

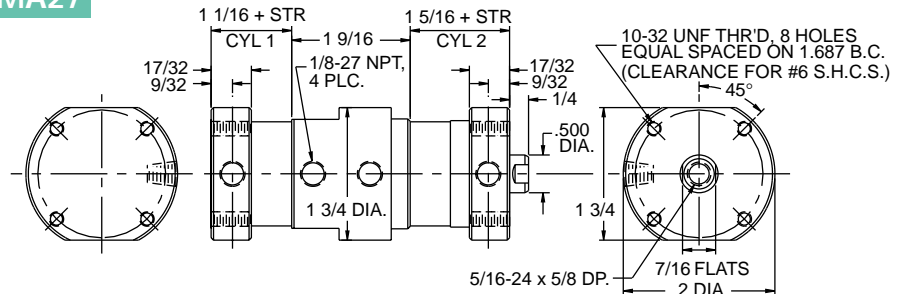

### SMA28

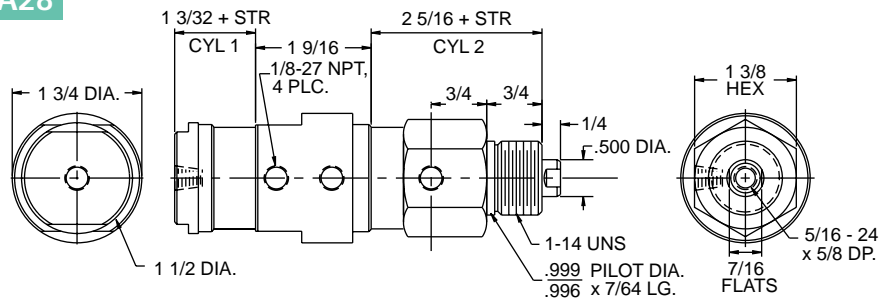

### SMA29

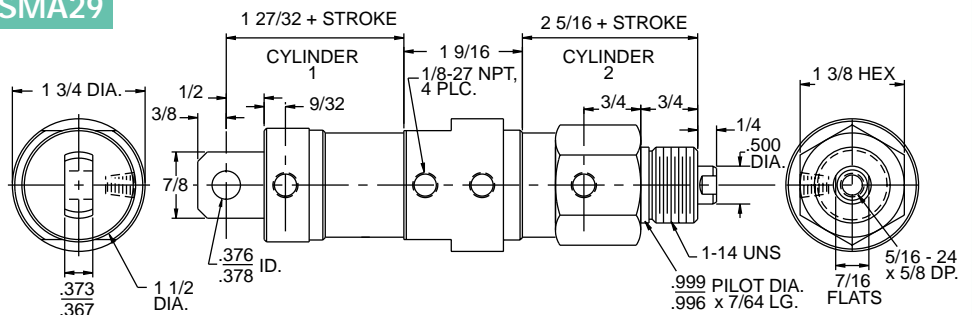

### SMA31

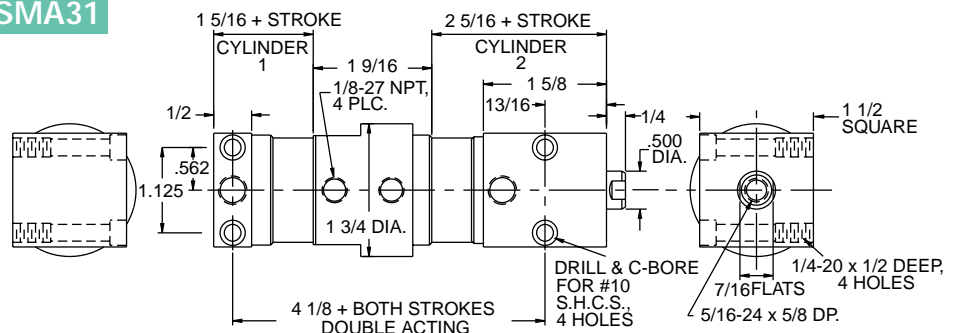

### STC -40

#### Low Profile Clevis Brk't

Used on SMA 26, 29  
Zinc plated steel

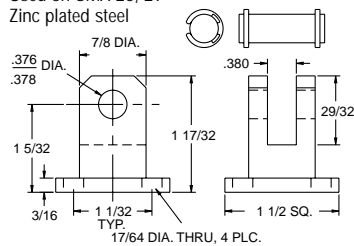

### HB-90

#### St'd Clevis Brk't

Used on SMA 26, 29  
Zinc plated steel

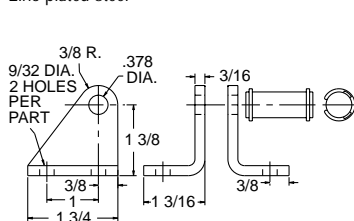



# 1 1/8" BORE SMA ALUMINUM

## Back to Back and Pump

Back to back cylinders are simply two standard double acting or single acting spring return cylinders with a common cap. By proper valve sequencing, four distinct stroke lengths may be achieved.

### SMA18

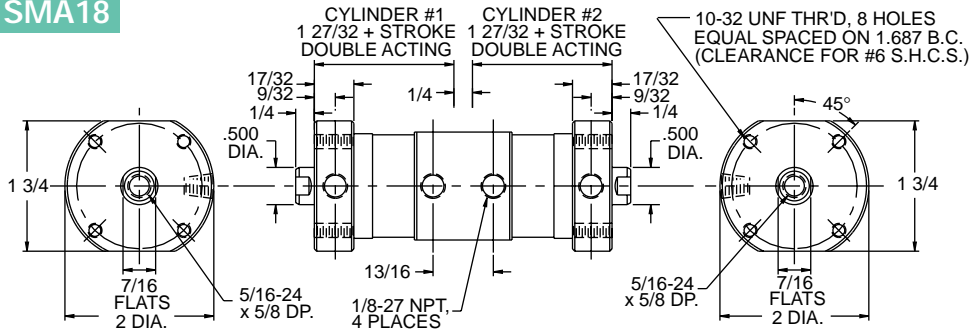

### SMA19

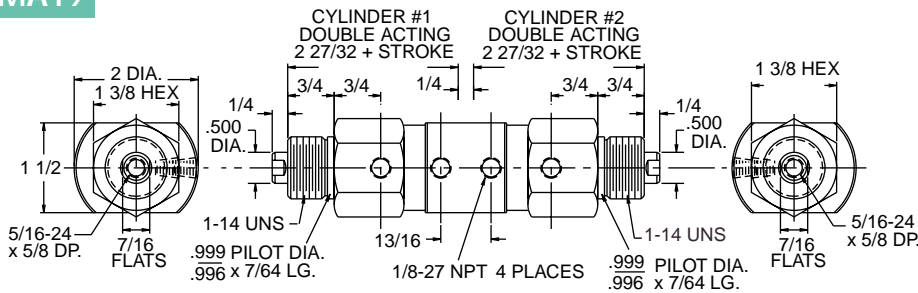

Shock pads

#### BACK TO BACK OPTIONS

Non-lube service

Viton seals

U cup piston

Magnetic piston

### Spring Return Cylinders

Pneumatic only  
Springs add to cyl. length  
0-2" stroke add 1 1/2" extra  
2 1/2-4" stroke add 3" extra  
over 4" stroke not available  
Spring force  
Fully extended—8#  
Fully compressed—20#  
Spring material—Plated steel

### Optional Male Rod Thread

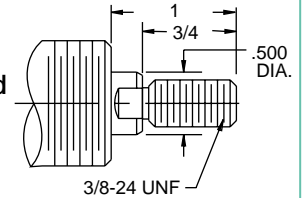

### HB-375 Rod Clevis & Nut

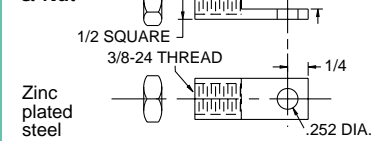

### HB 200 Clevis Pin Assembly

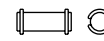

Used on HB 375 assembly  
Stainless pin/ steel clips

# 1 1/8" Bore SMA Volumetric Pump

**VOLUMETRIC PUMPS** measure and dispense specific volumes of fluid with compressed air. These tandem type cylinders have two pistons connected to a common rod. The air powered driver section is normally reciprocated with a four way valve. The inlet/discharge port is connected to a fluid supply line and a discharge line, both of which contain a check valve. On each stroke the pump section first draws in a specific volume of fluid from the supply line, and then forces it out the discharge line as both check valves shift. Maximum pressure of discharge fluid is approximately equal to the air pressure on the driver section. Standard construction materials are the same as all SMA cylinders – anodized aluminum tube and end caps, stainless rod, and brass pistons. Other materials, including all stainless construction, are available.

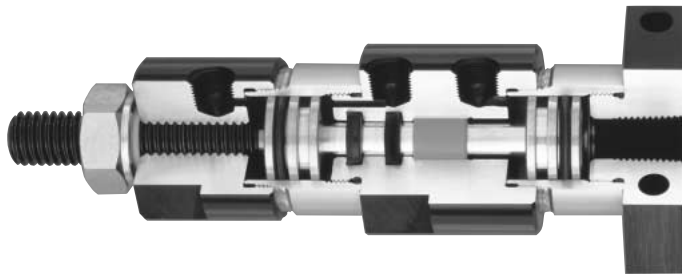

Special seal configurations are also available.

SMA 30 Volumetric Pumps are available only as double acting, pneumatic, and in 1" increments of stroke. U cup piston and shock pads not available.

### SMA30

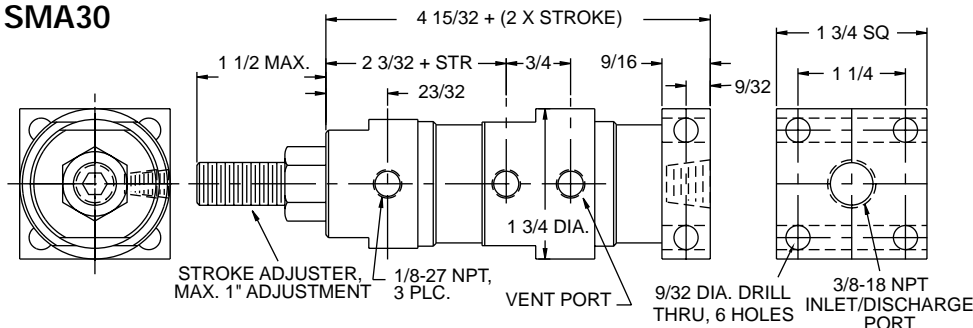

# Non-Rotate Option SMA Aluminum and SMS Stainless

Add a stainless tooling bar to prevent rotation on standard square or flange mount cylinders.

Guide bushings of P.E.T. plastic can be adjusted to take up wear. Superior registration can be achieved and maintained.

Hard chromed stainless guide rods.

Available on double acting cylinders in mounting styles SMA7, 8, 9, 12, 13, 14, 15, 17, 20, 24, and SMS7, 8, 9, 14, 15, 17.

Where space permits U cup piston with wear strip is recommended.

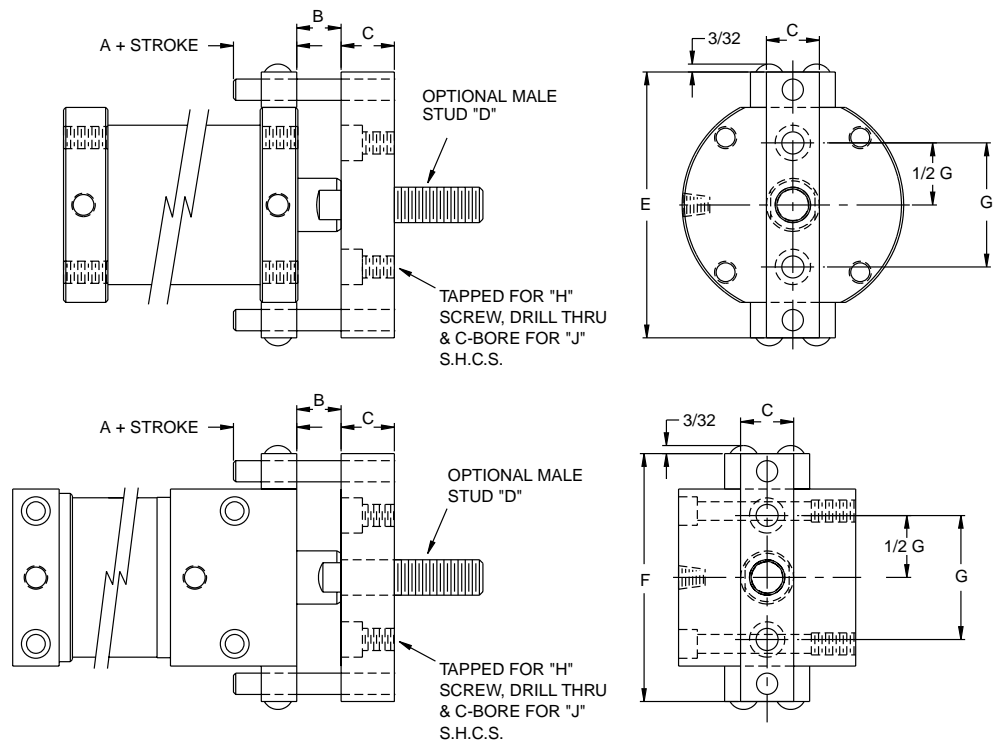
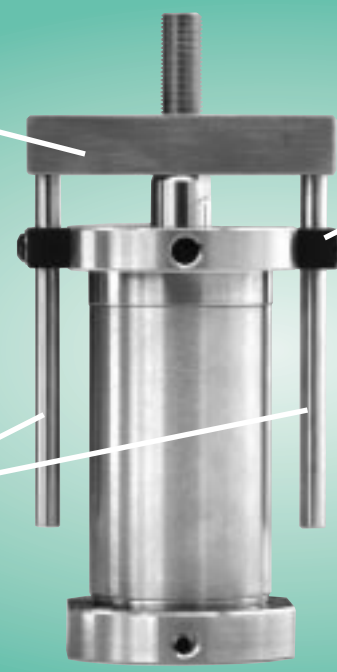

BORE	A	B	C	D	E	F	G	H	J
1 1/8	11/16	3/4	1/2	5/16-24 x 3/4	2 3/4	2 1/2	1.062	1/4-20	#10
1 1/2	11/16	5/8	5/8	3/8-24 x 1	3 1/4	3	1.250	5/16-18	1/4
2	9/16	5/8	3/4	1/2-20 x 1 1/4	3 3/4	3 1/2	1.750	5/16-18	1/4
3	NOT AVAILABLE								

# ORDERING PROCEDURE - SMA Aluminum



Select code numbers/letters (**bold type**) from each of the six boxes below - then select options desired from the table below. List codes in the same sequence as shown.

<table border="1" style="width: 100%; border-collapse: collapse;"> <thead> <tr> <th>Bore</th> <th>Code</th> </tr> </thead> <tbody> <tr><td>1 1/8"</td><td><b>11</b></td></tr> <tr><td>1 1/2"</td><td><b>15</b></td></tr> <tr><td>2"</td><td><b>20</b></td></tr> <tr><td>3"</td><td><b>30</b></td></tr> </tbody> </table>	Bore	Code	1 1/8"	<b>11</b>	1 1/2"	<b>15</b>	2"	<b>20</b>	3"	<b>30</b>		<table border="1" style="width: 100%; border-collapse: collapse;"> <thead> <tr> <th>Type</th> <th>Code</th> </tr> </thead> <tbody> <tr><td>Double acting</td><td><b>C</b></td></tr> <tr><td>Single acting spring return (Adds to cyl. length) Spring extend not available</td><td><b>A</b></td></tr> </tbody> </table>	Type	Code	Double acting	<b>C</b>	Single acting spring return (Adds to cyl. length) Spring extend not available	<b>A</b>	<table border="1" style="width: 100%; border-collapse: collapse;"> <thead> <tr> <th>Service</th> <th>Code</th> </tr> </thead> <tbody> <tr><td>Pneumatic</td><td><b>E</b></td></tr> <tr><td>Hydraulic</td><td><b>G</b></td></tr> <tr><td>SMA 30 always</td><td><b>E</b></td></tr> </tbody> </table>	Service	Code	Pneumatic	<b>E</b>	Hydraulic	<b>G</b>	SMA 30 always	<b>E</b>																																																																									
Bore	Code																																																																																																			
1 1/8"	<b>11</b>																																																																																																			
1 1/2"	<b>15</b>																																																																																																			
2"	<b>20</b>																																																																																																			
3"	<b>30</b>																																																																																																			
Type	Code																																																																																																			
Double acting	<b>C</b>																																																																																																			
Single acting spring return (Adds to cyl. length) Spring extend not available	<b>A</b>																																																																																																			
Service	Code																																																																																																			
Pneumatic	<b>E</b>																																																																																																			
Hydraulic	<b>G</b>																																																																																																			
SMA 30 always	<b>E</b>																																																																																																			
<table border="1" style="width: 100%; border-collapse: collapse;"> <thead> <tr> <th colspan="3">Mounting Style/Code</th> </tr> </thead> <tbody> <tr><td>SMA 1</td><td>SMA 11</td><td>SMA 21</td></tr> <tr><td>SMA 2</td><td>SMA 12</td><td>SMA 22</td></tr> <tr><td>SMA 3</td><td>SMA 13*</td><td>SMA 23</td></tr> <tr><td>SMA 5</td><td>SMA 14</td><td>SMA 24*</td></tr> <tr><td>SMA 6</td><td>SMA 15</td><td>SMA 25*</td></tr> <tr><td>SMA 7</td><td>SMA 16</td><td>SMA 26*</td></tr> <tr><td>SMA 8</td><td>SMA 17</td><td>SMA 27*</td></tr> <tr><td>SMA 9</td><td>SMA 18*</td><td>SMA 28*</td></tr> <tr><td>SMA 10</td><td>SMA 19*</td><td>SMA 29*</td></tr> <tr><td></td><td>SMA 20</td><td>SMA 30</td></tr> <tr><td></td><td></td><td>SMA 31*</td></tr> </tbody> </table>	Mounting Style/Code			SMA 1	SMA 11	SMA 21	SMA 2	SMA 12	SMA 22	SMA 3	SMA 13*	SMA 23	SMA 5	SMA 14	SMA 24*	SMA 6	SMA 15	SMA 25*	SMA 7	SMA 16	SMA 26*	SMA 8	SMA 17	SMA 27*	SMA 9	SMA 18*	SMA 28*	SMA 10	SMA 19*	SMA 29*		SMA 20	SMA 30			SMA 31*	<table border="1" style="width: 100%; border-collapse: collapse;"> <thead> <tr> <th>Stroke</th> </tr> </thead> <tbody> <tr><td>Code is stroke in total 1/8" increments Example: 1" stroke = <b>8</b> 2 1/4" stroke = <b>18</b></td></tr> <tr><td>Stocked in the following strokes: 1/8, 1/4, 3/8, 1/2, 3/4, 1, 1 1/4, 1 1/2, 1 3/4, 2 and 1/2" increments to 10"</td></tr> <tr><td>3" bore - Limited to 8" max. stroke</td></tr> <tr><td>Note: SMA 27, 28, 29, 31 available only 1/2" increments</td></tr> </tbody> </table>	Stroke	Code is stroke in total 1/8" increments Example: 1" stroke = <b>8</b> 2 1/4" stroke = <b>18</b>	Stocked in the following strokes: 1/8, 1/4, 3/8, 1/2, 3/4, 1, 1 1/4, 1 1/2, 1 3/4, 2 and 1/2" increments to 10"	3" bore - Limited to 8" max. stroke	Note: SMA 27, 28, 29, 31 available only 1/2" increments	<table border="1" style="width: 100%; border-collapse: collapse;"> <thead> <tr> <th colspan="4">Piston Rod Codes</th> </tr> <tr> <th>Bore</th> <th>Thread</th> <th></th> <th>Code</th> </tr> </thead> <tbody> <tr><td>1.125</td><td>3/8-24 x 3/4</td><td>Male</td><td><b>M6</b></td></tr> <tr><td>1.125</td><td>5/16-18 x 5/8</td><td>Female</td><td><b>F3</b></td></tr> <tr><td>1.125</td><td>5/16-24 x 5/8</td><td>Female</td><td><b>F4</b></td></tr> <tr><td>1.500</td><td>1/2-20 x 1</td><td>Male</td><td><b>M8</b></td></tr> <tr><td>1.500</td><td>3/8-16 x 5/8</td><td>Female</td><td><b>F5</b></td></tr> <tr><td>1.500</td><td>3/8-24 x 5/8</td><td>Female</td><td><b>F6</b></td></tr> <tr><td>2.000</td><td>5/8-18 x 1 1/8</td><td>Male</td><td><b>M12</b></td></tr> <tr><td>2.000</td><td>1/2-20x 3/4</td><td>Female</td><td><b>F8</b></td></tr> <tr><td>3.000</td><td>3/4-16 x 1 1/4</td><td>Male</td><td><b>M10</b></td></tr> <tr><td>3.000</td><td>3/4-16 x 1</td><td>Female</td><td><b>F10</b></td></tr> <tr><td colspan="3">With non-rotate option enter code</td><td><b>11</b></td></tr> <tr><td colspan="3">For style SMA 30 enter code</td><td><b>11</b></td></tr> </tbody> </table>	Piston Rod Codes				Bore	Thread		Code	1.125	3/8-24 x 3/4	Male	<b>M6</b>	1.125	5/16-18 x 5/8	Female	<b>F3</b>	1.125	5/16-24 x 5/8	Female	<b>F4</b>	1.500	1/2-20 x 1	Male	<b>M8</b>	1.500	3/8-16 x 5/8	Female	<b>F5</b>	1.500	3/8-24 x 5/8	Female	<b>F6</b>	2.000	5/8-18 x 1 1/8	Male	<b>M12</b>	2.000	1/2-20x 3/4	Female	<b>F8</b>	3.000	3/4-16 x 1 1/4	Male	<b>M10</b>	3.000	3/4-16 x 1	Female	<b>F10</b>	With non-rotate option enter code			<b>11</b>	For style SMA 30 enter code			<b>11</b>	
Mounting Style/Code																																																																																																				
SMA 1	SMA 11	SMA 21																																																																																																		
SMA 2	SMA 12	SMA 22																																																																																																		
SMA 3	SMA 13*	SMA 23																																																																																																		
SMA 5	SMA 14	SMA 24*																																																																																																		
SMA 6	SMA 15	SMA 25*																																																																																																		
SMA 7	SMA 16	SMA 26*																																																																																																		
SMA 8	SMA 17	SMA 27*																																																																																																		
SMA 9	SMA 18*	SMA 28*																																																																																																		
SMA 10	SMA 19*	SMA 29*																																																																																																		
	SMA 20	SMA 30																																																																																																		
		SMA 31*																																																																																																		
Stroke																																																																																																				
Code is stroke in total 1/8" increments Example: 1" stroke = <b>8</b> 2 1/4" stroke = <b>18</b>																																																																																																				
Stocked in the following strokes: 1/8, 1/4, 3/8, 1/2, 3/4, 1, 1 1/4, 1 1/2, 1 3/4, 2 and 1/2" increments to 10"																																																																																																				
3" bore - Limited to 8" max. stroke																																																																																																				
Note: SMA 27, 28, 29, 31 available only 1/2" increments																																																																																																				
Piston Rod Codes																																																																																																				
Bore	Thread		Code																																																																																																	
1.125	3/8-24 x 3/4	Male	<b>M6</b>																																																																																																	
1.125	5/16-18 x 5/8	Female	<b>F3</b>																																																																																																	
1.125	5/16-24 x 5/8	Female	<b>F4</b>																																																																																																	
1.500	1/2-20 x 1	Male	<b>M8</b>																																																																																																	
1.500	3/8-16 x 5/8	Female	<b>F5</b>																																																																																																	
1.500	3/8-24 x 5/8	Female	<b>F6</b>																																																																																																	
2.000	5/8-18 x 1 1/8	Male	<b>M12</b>																																																																																																	
2.000	1/2-20x 3/4	Female	<b>F8</b>																																																																																																	
3.000	3/4-16 x 1 1/4	Male	<b>M10</b>																																																																																																	
3.000	3/4-16 x 1	Female	<b>F10</b>																																																																																																	
With non-rotate option enter code			<b>11</b>																																																																																																	
For style SMA 30 enter code			<b>11</b>																																																																																																	

Option	Description	Code
Extra rod extension 1/4 " increments	Specify code letter <b>J</b> followed by extra length required as a two place decimal Example: <b>J.50</b> = 1/2" extra <b>J1.25</b> = 1 1/4"extra	<b>J</b>
Shock pads	Add to either or both ends in 1 1/8", 1 1/2", 2" bore up to 2" stroke.	Rod end only <b>L</b>
Pneu. only to 180° F	Over 2" stroke and on all 3" bore must be added to both ends Each pad adds	Cap end only <b>M</b>
Double acting only	1/4" length — not available SMA 12, 13, 20, 21, 24, 25, 26, 27, 28, 29, 30, 31	Both ends <b>N</b>
Non-lube service	Available on standard O ring Piston. Not available or necessary on U cup piston	<b>P</b>
Viton seals	Standard seals are nitrile and urethane +10 to +200° F For service -10 to +400° F specify viton	<b>R</b>
U cup piston	Extends cycle life and reduces friction Piston is aluminum and includes teflon wear strip — adds 1/2" to length Not available SMA 27, 28, 29, 30, 31	<b>S</b>
Clevis 90° to std	SMA 2, 16, 26, 29, only	<b>T</b>
Magnetic piston	Adds 1/2" to length — not available SMA 27, 28, 29, 31	<b>W</b>
Non rotate	Available only on double acting SMA 7, 8, 9, 12, 13, 14, 15, 17, 20, 24	with male stud <b>X</b> without male stud <b>Y</b>
1/4" oversize ports	2" bore only — SMA 1, 2, 3, 6, 7, 8, 9, only Not available with option x,y	<b>Z</b>

**Part No. Example:**

1.500 bore
Mounting style SMA9
1.500 stroke
1 1/2-20 x 1 male thread
Magnetic piston

15 SMA9 C 12 E M8 R W

Double acting
Pneumatic
Viton seals

\* These models are combinations of two cylinders with a common cap. The dimensional drawings illustrate them as being composed of a cylinder #1 section and a cylinder #2 section. The part number also contains 2 sections. Compose the part number for cylinder #1 as shown above. Mounting styles SMA 13, 24, 25, 26, 27, 28, 29, 31 will always have piston rod code 11. Then add a dash (-) and the part number for cylinder #2 skipping the "bore" and "mounting style" codes and beginning with the "type" code.

**Example:**

← Cylinder 1 →
← Cylinder 2 →

11 SMA 18 C 10 E 11 R
-
C 16 E F 3 R

# SMA Service Parts

When ordering any repair part please provide the part number and description shown below along with the serial number and part number of the cylinder being serviced.

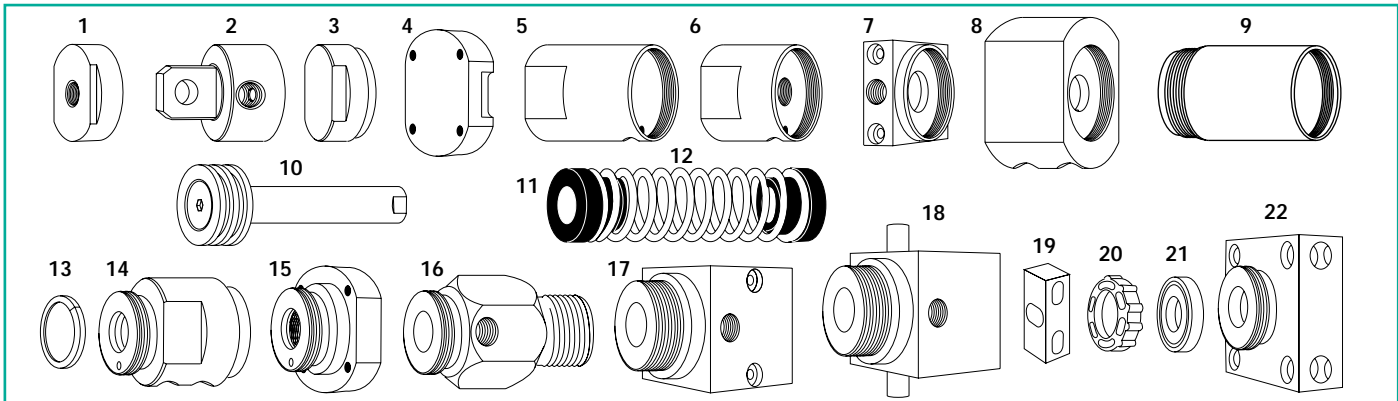

Key	Description	1 1/8 Bore	1 1/2 Bore	2 Bore	3 Bore
<b>Seal kits for standard cylinders with O ring piston — SMA 1, 2, 3, 5, 6, 7, 8, 9, 10, 11, 12, 14, 15, 16, 17, 20, 21, 22, 23</b>					
	Pneumatic, Nitrile Add suffix NL for Non-Lube	SMA 3411	SMA 3415	SMA 3420	SMA 3430
	Pneumatic, Viton Add suffix NL for Non-Lube	SMA 3411V	SMA 3415V	SMA 3420V	SMA 3430V
	Hydraulic, Nitrile	SMA 3511	SMA 3515	SMA 3520	SMA 3530
	Hydraulic, Viton	SMA 3511V	SMA 3515V	SMA 3520V	SMA 3530V
<b>Seal kits for standard cylinders with U cup piston — SMA 1, 2, 3, 5, 6, 7, 8, 9, 10, 11, 12, 14, 15, 16, 17, 20, 21, 22, 23</b>					
	Pneumatic, Nitrile	SMA 5411	SMA 5415	SMA 5420	SMA 5430
	Pneumatic, Viton	SMA 5411V	SMA 5415V	SMA 5420V	SMA 5430V
	Hydraulic, Nitrile	SMA 5511	SMA 5515	SMA 5520	SMA 5530
	Hydraulic, Viton	SMA 5511V	SMA 5515V	SMA 5520V	SMA 5530V
<b>Seal kits for combination cylinders with O Ring piston — SMA 13, 18, 19, 24, 25, 26, 27, 28, 29, 30, 31</b>					
	Pneumatic, Nitrile Add suffix NL for Non-Lube	SMA 3611	SMA 3615	SMA 3620	SMA 3630
	Pneumatic, Viton Add suffix NL for Non-Lube	SMA 3611V	SMA 3615V	SMA 3620V	SMA 3630V
	Hydraulic, Nitrile	SMA 3711	SMA 3715	SMA 3720	SMA 3730
	Hydraulic, Viton	SMA 3711V	SMA 3715V	SMA 3720V	SMA 3730V
<b>Seal kits for combination cylinders with U cup piston — SMA 13, 18, 19, 24, 25, 26</b>					
	Pneumatic, Nitrile	SMA 5611	SMA 5615	SMA 5620	SMA 5630
	Pneumatic, Viton	SMA 5611V	SMA 5615V	SMA 5620V	SMA 5630V
	Hydraulic, Nitrile	SMA 5711	SMA 5715	SMA 5720	SMA 5730
	Hydraulic, Viton	SMA 5711V	SMA 5715V	SMA 5720V	SMA 5730V
1	Rear port cap Add suffix 250 for 2" bore 1/4 NPT	SMA 1011	SMA 1015	SMA 1020	SMA 1030
2	Rear pivot cap Add suffix 250 for 2" bore 1/4 NPT	SMA 1111	SMA 1115	SMA 1120	SMA 1130
2	90° Rear pivot cap Add suffix 250 for 2" bore 1/4 NPT	SMA 111190	SMA 111590	SMA 112090	SMA 113090
3	Side port cap Add suffix 250 for 2" bore 1/4 NPT	SMA 4811	SMA 4815	SMA 4820	SMA 4830
4	Rear flange cap	SMA 1311	SMA 1315	SMA 1320	SMA 1330
5	Spherical bearing cap	SMA 2211	SMA 2215	SMA 2220	SMA 2230
6	Adjustable stroke cap	SMA 2011	SMA 2015	SMA 2020	
7	Square cap Add suffix 250 for 2" bore 1/4 NPT	SMA 4611	SMA 4615	SMA 4620	
8	Back to back body	SMA 1811	SMA 1815	SMA 1820	SMA 1830
9	Tube	part No. is T followed by the complete cylinder part number			
10	Piston rod assembly	part No. is PR followed by the complete cylinder part number			
11	Spring guide Pair	SMA 1211	SMA 1215	SMA 1220	SMA 1230
12	Spring	11215	15015	20015	20015
13	Magnet SMS5911 and SS3215 supplied in pairs	SMS 5911	SS 3215	SS 3220	SS 3230
14	3 position/Tandem/Pump body	SMA 2411	SMA 2415	SMA 2420	SMA 2430
15	Flange head Add suffix NR for non-rotate	SMA 1411	SMA 1415	SMA 1420	SMA 1430
16	Nose Mount Head Add suffix 250 for 2" bore, 1/4 NPT	SMA 0111	SMA 0115	SMA 0120	SMA 0130
17	Short square Head Add suffix 250 for 2" bore, 1/4 NPT	SMA 4411	SMA 4415	SMA 4420	
17	Long square Head Add suffix 250 for 2" bore, 1/4 NPT	SMA 4511	SMA 4515	SMA 4520	
17	Square non rotate head	SMA 4511NR	SMA 4515NR	SMA 4520NR	
18	Trunnion head	SMA 4511T	SMA 4515T	SMA 4520T	
19	Non-rotate guide bushing Pair	SMS 5111	SMS 5111	SMS 5111	
20	Cap end shock pad	Consult factory			3MSP
21	Head end shock pad	11CSP	15CSP	2CSP	3MSP
22	SMA 30 cap	SMA 6011	SMA 6015	SMA 6020	